



Capacity to 900 GPM (210 M³/hr)

Pressure to 190 PSI (13 Bar)

Viscosity to 2,700 SSU (600 cPs)

Temperature to 380° F (195° C)



HYGIENIC CENTRIFUGAL PUMPS TRA[®] 500 Series

wrightflow
TECHNOLOGIES

IDEX
IDEX CORPORATION

The TRA[®]500 Series Centrifugal Pump

With its proven design, Wright Flow Technologies' TRA[®]500 series centrifugal pumps provide processors a lower cost of ownership with its ease of installation, ease of maintenance, and reduced parts inventory.

Built with close internal tolerances for exceptionally low NPSH (Net Positive Suction Head), forward-thinking impeller design, and only 316L stainless steel wetted components, the TRA[®]500 series is your ideal solution for all areas of dairy, food processing, beverage, biopharm, and other

demanding hygienic applications. What's more, the series meets the most stringent hygienic standards for being CIP-able and SIP-able.

The TRA[®]500 Series of hygienic centrifugal pumps are offered in both non-volute (circular) and volute style housings. The non-volute TRA[®]50 models provides superior low flow efficiency and offer enhanced accuracy with controlling devices.

The TRA[®]55 and TRA[®]54 model's volute style housings are for applications that require steady discharge pressures at higher capacities over a wide range of flows.

When it comes to quality, Wright Flow Technologies tests each TRA[®]500 series pump to ensure performance from day one and beyond. The fourteen sizes and many options of this centrifugal series ensure you have the right solution that precisely matches your specific application construction needs.



TRA[®]500 Series Construction

- ▶ Cast 316L stainless steel.
- ▶ Exclusive "no weld" clamp style connections on TRA[®]500, 501, 502, 503, 504, 505, 506 models – clamp style connection fittings are "machined-in-place".
- ▶ Integral inlet/outlet in the housing for ease of maintenance.
- ▶ Stainless steel flange adapters (motor to pump head) are standard – no painted cast iron.
- ▶ Fully adjustable head orientation for installation flexibility.
- ▶ Full material traceability and material certification available.
- ▶ Exterior surfaces are polished for the ultimate clean look – no "as cast" surfaces.
- ▶ One size seal fits all – up through 30 Hp (22 kW).
- ▶ Pumps can be changed from single to double mechanical seals without changing shafts or flange adapters.
- ▶ Full wear and spare part interchangeability of seals, gaskets, impeller nuts, impellers, and much more.

Typical Applications

- ▶ **Beverages:** high fructose corn syrup, single strength fruit juices, beer, water, liquors, wine, wort, yeast slurries
- ▶ **Dairy:** milk, cream, whey (up to 50% solids), ice cream mix, buttermilk
- ▶ **Confectionery:** sugar solutions, chocolate, corn syrup
- ▶ **Oils:** cooking, frying, salad
- ▶ **Personal Care:** mouthwash, cologne, after shave
- ▶ **Cosmetics:** shampoo, lotions
- ▶ **CIP:** solutions, caustics, enzyme cleaners, sanitizers
- ▶ **Pharmaceuticals and biotech:** process waters (RO, DI, Analytical)



A Lower Cost of Ownership for Processors

Today's consumers expect an ever increasing array of top quality foods and beverages to be continuously available, while being produced with absolute quality and integrity – at the lowest possible price. Consequently, this results in a fiercely competitive marketplace with severe pressure to reduce total cost of ownership.

The TRA[®]500 Series centrifugal pump from Wright Flow Technologies is your solution to a lower cost of ownership while providing the flexibility your operations need. Its simple, robust cast 316L stainless steel construction provides the durability, integrity, and absolute quality required for your sanitary fluid transfer operations.

Pump installation has never been easier - the fully adjustable flange/pump head of the TRA[®]500 Series' provides

superior orientation for faster, easier, better fit to your system. Self-alignment occurs naturally with the series' simple shaft lock collar that requires no special tools. With its machined-in-place, "no-weld" sanitary clamp fittings on most models, you're guaranteed of the highest integrity connections.

Maintenance is made simple with the TRA[®]500 Series' integral inlet/outlet housing ports, which provide better serviceability of the series' back pull out design. They also eliminate the extra service requirement and leak potential associated with piping realignment. Adding to simplified maintenance is the front pull out cartridge seal option that eliminates pump head removal for seal change out. Clean-up is more effective with the TRA 500 Series because of its standard

stainless steel flange adapters that eliminates the paint chipping and rust associated with traditional cast iron flanges. Additionally, the polished exterior pump surfaces ensures successful cleaning, and enhances the appearance.

The TRA[®]500 Series will reduce your maintenance inventory significantly with its interchangeability of virtually all wear and spare parts such as seals, gaskets, impellers and more.

Best of all, the fourteen sizes of TRA[®]500 series centrifugal pumps are designed to be dimensionally interchangeable, drop-in replacements for other leading brands of sanitary centrifugal pumps. Contact your local authorized Wright Flow Technologies Distributor for details.

Shaft Sealing Options

Single or Double Internal Mechanical Seal

- ▶ Choice of open spring or cartridge
- ▶ Standard seal faces include:
 - ▶ Chrome Oxide
 - ▶ Carbon
 - ▶ Silicon Carbide
- ▶ Standard elastomers of Viton[®]
- ▶ Optional elastomers:
 - ▶ EPDM
 - ▶ PTFE
 - ▶ FKM
 - ▶ USP Class VI
 - ▶ Silicone
 - ▶ Chemraz[®]
 - ▶ Kalrez[®]
 - ▶ Nitrile

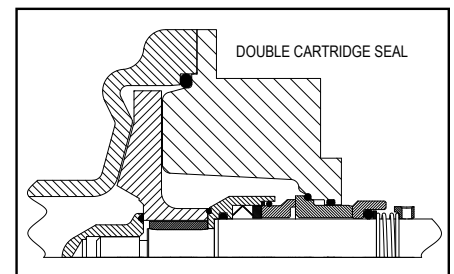
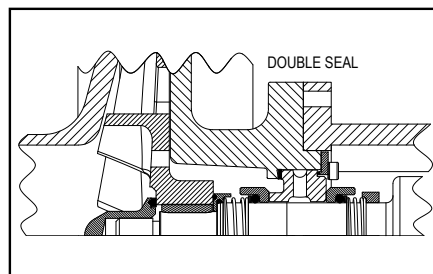
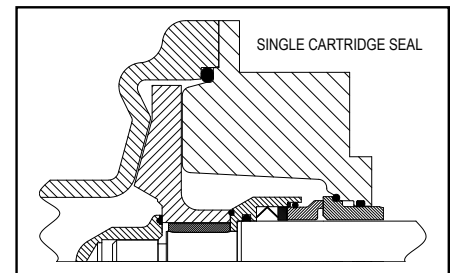
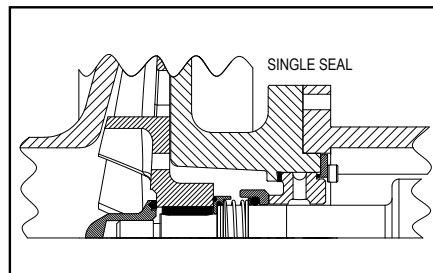

Chemraz[®] is a registered trademark of Greene, Tweed & Co.
Kalrez[®] is a registered trademark of DuPont Performance Elastomers.
Viton[®] is a registered trademark of DuPont Performance Elastomers.

Wright TRA[®]500 Series Features & Benefits

◀ Machined-In-Place Ports ▶

Integral inlet and outlet ports are machined-in-place providing “no-weld” sanitary clamp-style fittings (through model TRA[®]506) that eliminate welding, ensuring the highest uniform integrity. Only 1 weld on all other models.

◀ Fully Adjustable Flange Adapter ▶

Fully adjustable flange adapter/pump head orientation for best fit-up and fine adjustment in hard to reach piping arrangements.

◀ Corrosion Resistant Flange Adapter ▶

Durable, stainless steel flange adapter eliminates the painted cast iron parts that can chip and rust, which may require regular maintenance.

◀ Shaft Lock Collar ▶

Simple shaft lock collar permits quick, easy installation while providing self-alignment, with no special tool requirements.

◀ ‘Drop-In’ Replacement Design ▶

The TRA[®]500 Series are dimensionally interchangeable with other manufacturers, contact your local authorized Wright Flow Technologies Distributor for more details.

◀ Product Integrity ▶

The TRA[®]500 Series is CIP-able and SIP-able. Its impeller is designed for gentle handling of shear sensitive products. Impellers are dynamically balanced to ISO 1940/1 standards. Heavy-wall, cast 316L stainless steel construction extends service life and minimizes vibration.

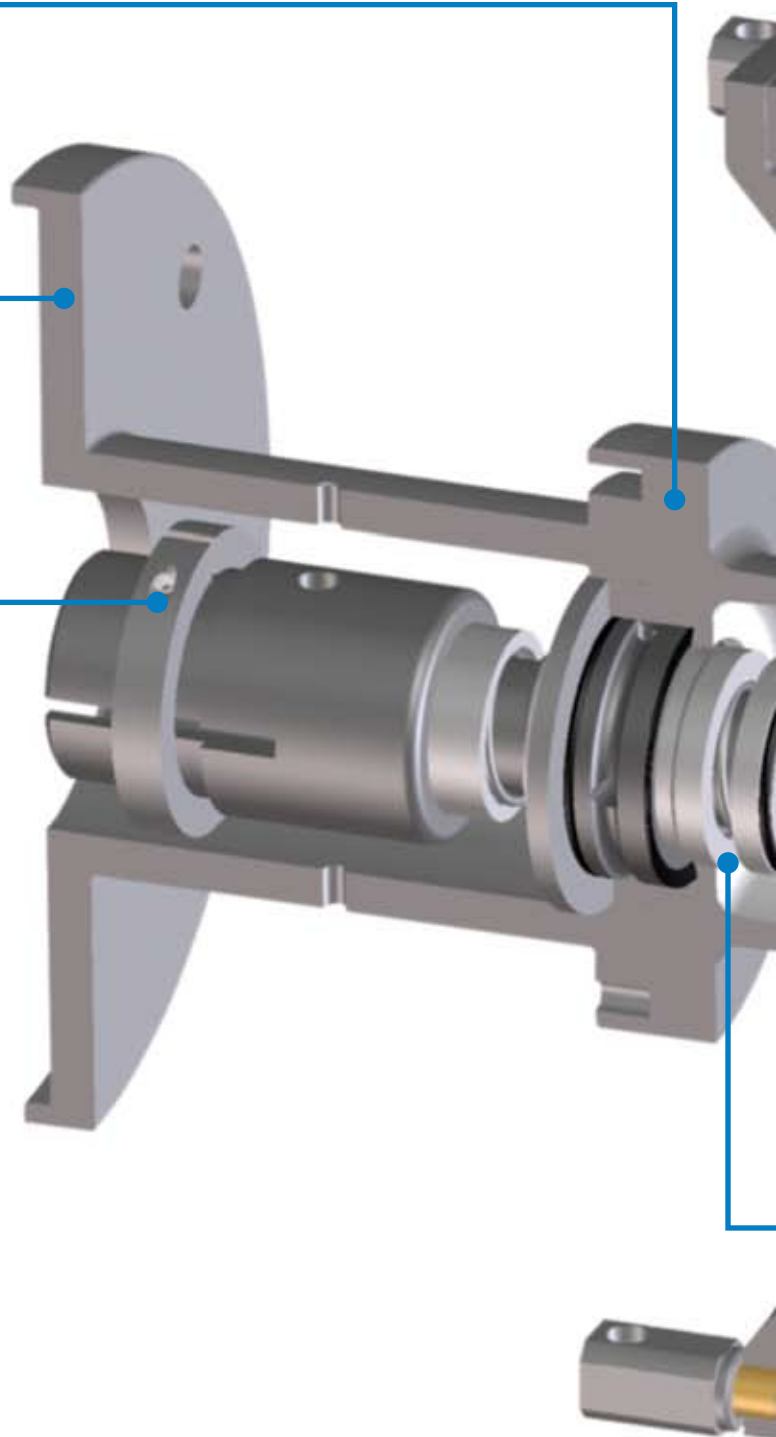

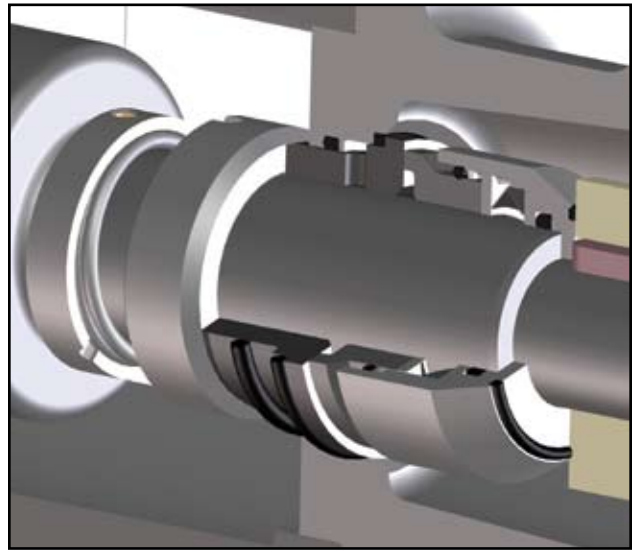
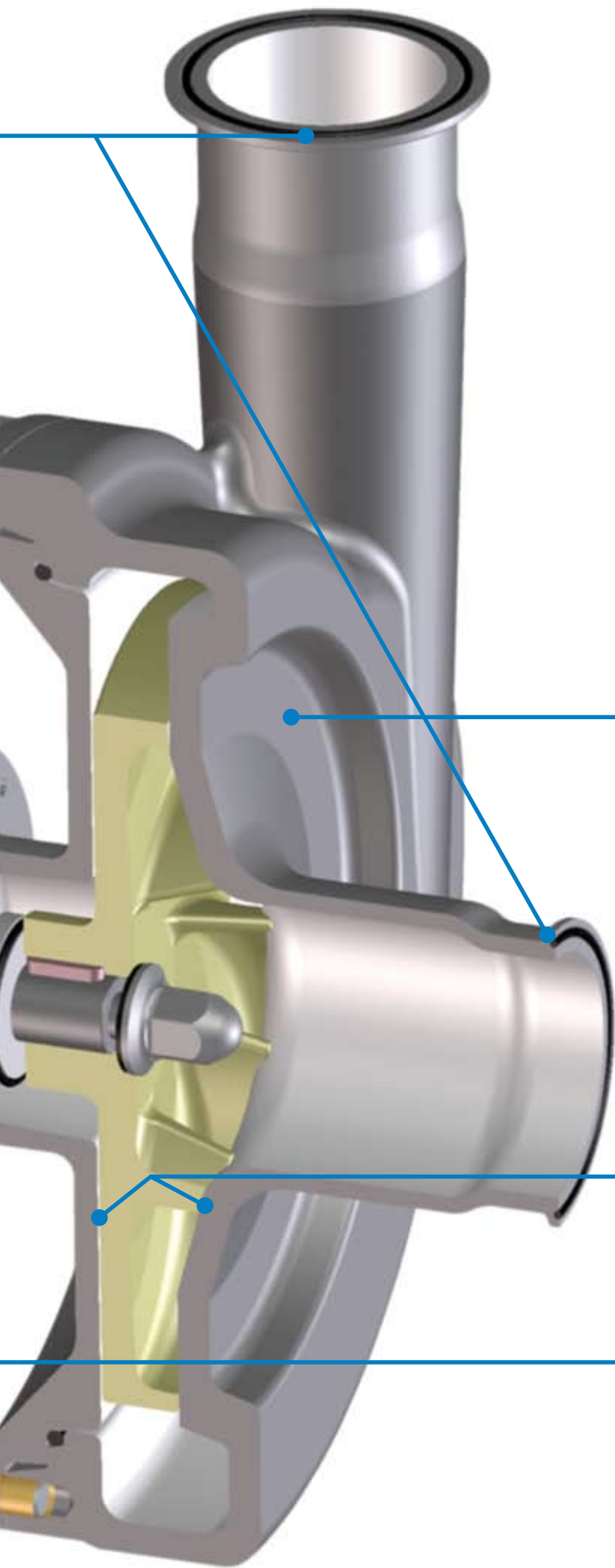

For global application capabilities, the TRA500 series' front-pull out seal design simplifies inventory needs and maintenance with its in-line serviceability, which eliminates the need for pump removal from the system, saving time and effort. Front-pull out seal meets all applicable EHEDG and 3-A requirements.

◀ **Polished Exterior Surfaces** ▶

Exterior pump surfaces are polished, no “as cast” pump exterior surfaces provide the ultimate in easy-to-clean appearance.

◀ **Reduced Maintenance Inventory** ▶

Two sizes of mechanical seals fit the entire line, with one size fitting the TRA®500 series models through 30 HP (22 Kw). The series also provides full wear and spare part interchangeability of seals, gaskets, impeller nuts, impellers, and much more - reducing maintenance inventory.

◀ **Exceptionally Low NPSH** ▶

Very small clearances affords low NPSH, ideal for vacuum, liquids with low viscosity, high temperatures or low NPSHA conditions.

◀ **Customized Sealing Options** ▶

Standard universal open spring design or cartridge. Tailored sealing solutions available for virtually every liquid and application. Changing from single- to double-mechanical seal is simple and does not require optional shafts or flange adapters to be purchased.

TRA[®]500 Series Flow Ratings

Model	1750 RPM		3500 RPM		1450 RPM		2900 RPM	
	Flow Range	Pressure Range	Flow Range	Pressure Range	Flow Range	Pressure Range	Flow Range	Pressure Range
TRA [®] 500	2 to 40 GPM	4 to 6.5 PSI	4 to 80 GPM	13 to 25 PSI	1 to 25 GPM	1 to 6 PSI	2 to 40 GPM	12 to 21 PSI
	0.5 to 9.4 M ³ /hr.	0.3 to 0.4 BAR	0.9 to 18.8 M ³ /hr.	0.9 to 1.7 BAR	0.3 to 5.7 M ³ /hr.	0.1 to 0.4 BAR	0.5 to 9.1 M ³ /hr.	0.8 to 1.74 BAR
TRA [®] 501	5 to 60 GPM	8 to 12 PSI	9 to 120 GPM	28 to 43 PSI	4 to 50 GPM	3.5 to 7 PSI	6 to 80 GPM	18 to 28 PSI
	1.2 to 14.1 M ³ /hr.	0.5 to 0.8 BAR	2.1 to 28.2 M ³ /hr.	1.9 to 2.9 BAR	0.9 to 11.4 M ³ /hr.	0.2 to 0.5 BAR	1.4 to 18.2 M ³ /hr.	1.3 to 1.9 BAR
TRA [®] 502	7 to 90 GPM	8 to 15 PSI	10 to 140 GPM	32 to 60 PSI	5 to 61 GPM	1 to 11 PSI	7 to 135 GPM	16 to 44 PSI
	1.6 to 21.2 M ³ /hr.	0.5 to 1 BAR	2.4 to 32.9 M ³ /hr.	2.2 to 4.1 BAR	1.1 to 13.6 M ³ /hr.	0.5 to 0.7 BAR	1.5 to 30.7 M ³ /hr.	1.1 to 3 BAR
TRA [®] 503	10 to 100 GPM	14 to 18 PSI	N/A	N/A	5 to 62 GPM	11 to 15 PSI	N/A	N/A
	2.4 to 23.5 M ³ /hr.	1 to 1.2 BAR			1.1 to 14 M ³ /hr.	0.8 to 1.1 BAR		
TRA [®] 504	N/A	N/A	12 to 150 GPM	38 to 77 PSI	N/A	N/A	7 to 132 GPM	10 to 61 PSI
			2.8 to 35.3 M ³ /hr.	2.6 to 5.2 BAR			1.5 to 30 M ³ /hr.	0.7 to 4.2 BAR
TRA [®] 505	10 to 120 GPM	22 to 28 PSI	16 to 200 GPM	80 to 109 PSI	8 to 100 GPM	9 to 20 PSI	15 to 150 GPM	53 to 81 PSI
	2.4 to 28.2 M ³ /hr.	1.5 to 1.9 BAR	3.8 to 47 M ³ /hr.	5.4 to 7.4 BAR	1.8 to 22.6 M ³ /hr.	0.7 to 1.4 BAR	3.4 to 34 M ³ /hr.	3.6 to 5.6 BAR
TRA [®] 506	15 to 170 GPM	23 to 34 PSI	25 to 300 GPM	88 to 130 PSI	12 to 141 GPM	11 to 22 PSI	24 to 242 GPM	58 to 86 PSI
	3.5 to 40 M ³ /hr.	1.6 to 2.3 BAR	5.9 to 71 M ³ /hr.	6 to 8.8 BAR	2.6 to 32 M ³ /hr.	0.8 to 1.5 BAR	5.5 to 55 M ³ /hr.	4 to 6 BAR
TRA [®] 552	15 to 175 GPM	8 to 16 PSI	25 to 350 GPM	33 to 65 PSI	13 to 160 GPM	4 to 10 PSI	17 to 220 GPM	30 to 43 PSI
	3.5 to 41.1 M ³ /hr.	0.5 to 1.1 BAR	5.9 to 82.3 M ³ /hr.	2.2 to 4.4 BAR	2.9 to 36.3 M ³ /hr.	0.3 to 0.7 BAR	4 to 50 M ³ /hr.	2.1 to 2.9 BAR
TRA [®] 553	20 to 250 GPM	12 to 23 PSI	40 to 400 GPM	46 to 94 PSI	16 to 200 GPM	8 to 16 PSI	35 to 350 GPM	26 to 62 PSI
	4.7 to 59 M ³ /hr.	0.8 to 1.6 BAR	9.4 to 94 M ³ /hr.	3.1 to 6.4 BAR	3.7 to 45.4 M ³ /hr.	0.5 to 1.1 BAR	8 to 80 M ³ /hr.	1.8 to 4.3 BAR
TRA [®] 554	25 to 350 GPM	15 to 30 PSI	50 to 700 GPM	87 to 132 PSI	25 to 300 GPM	7 to 21 PSI	43 to 616 GPM	28 to 85 PSI
	5.9 to 82.3 M ³ /hr.	1 to 2 BAR	11.8 to 165 M ³ /hr.	5.9 to 9 BAR	5.5 to 68.1 M ³ /hr.	0.5 to 1.4 BAR	10 to 140 M ³ /hr.	1.9 to 5.8 BAR
TRA [®] 545	25 to 275 GPM	22 to 42 PSI	50 to 450 GPM	88 to 165 PSI	25 to 248 GPM	9 to 28 PSI	39 to 396 GPM	67 to 116 PSI
	5.9 to 64.6 M ³ /hr.	1.5 to 2.9 BAR	11.8 to 106 M ³ /hr.	6 to 11.2 BAR	5.7 to 56.5 M ³ /hr.	0.6 to 1.9 BAR	9 to 90 M ³ /hr.	4.6 to 8 BAR
TRA [®] 555	60 to 600 GPM	27 to 47 PSI	60 to 600 GPM	110 to 190 PSI	55 to 532 GPM	14 to 36 PSI	50 to 528 GPM	68 to 134 PSI
	14 to 136 M ³ /hr.	1.8 to 3.2 BAR	14 to 136 M ³ /hr.	7.5 to 12.9 BAR	12.5 to 121 M ³ /hr.	0.9 to 2.5 BAR	12 to 120 M ³ /hr.	4.7 to 9.2 BAR
TRA [®] 558	100 to 900 GPM	40 to 55 PSI	N/A	N/A	96 to 762 GPM	25 to 38 PSI	N/A	N/A
	23.5 to 212 M ³ /hr.	2.7 to 3.7 BAR			22 to 173 M ³ /hr.	1.78 to 2.6 BAR		
TRA [®] 559	100 to 800 GPM	57 to 78 PSI	N/A	N/A	84 to 678 GPM	40 to 53 PSI	N/A	N/A
	23.5 to 188 M ³ /hr.	3.9 to 5.3 BAR			19 to 154 M ³ /hr.	2.8 to 3.7 BAR		

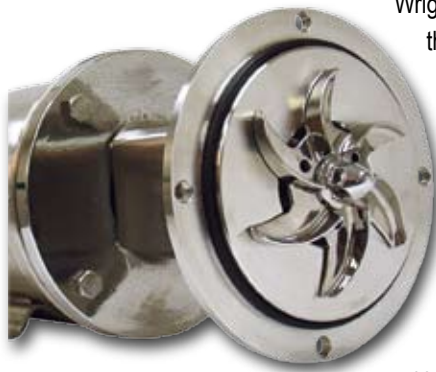

Wright Flow Technologies' solid design of the TRA[®]500 Series and use of only high grade 316L stainless steel provides you the operational reliability, superior corrosion resistance, and unsurpassed performance you've come to expect in an industry leader. Wright Flow Technologies supports and participates in the applicable hygienic industry organizations, striving for continuous improvements for operation, cleanliness and design.

TRA®500 Performance Curves

Performance curves shown are based on tests using 70°F (20°C) water. A tolerance of +/- 5% applies to all figures. Refer to individual curves for detailed information. *Contact factory for different conditions.*

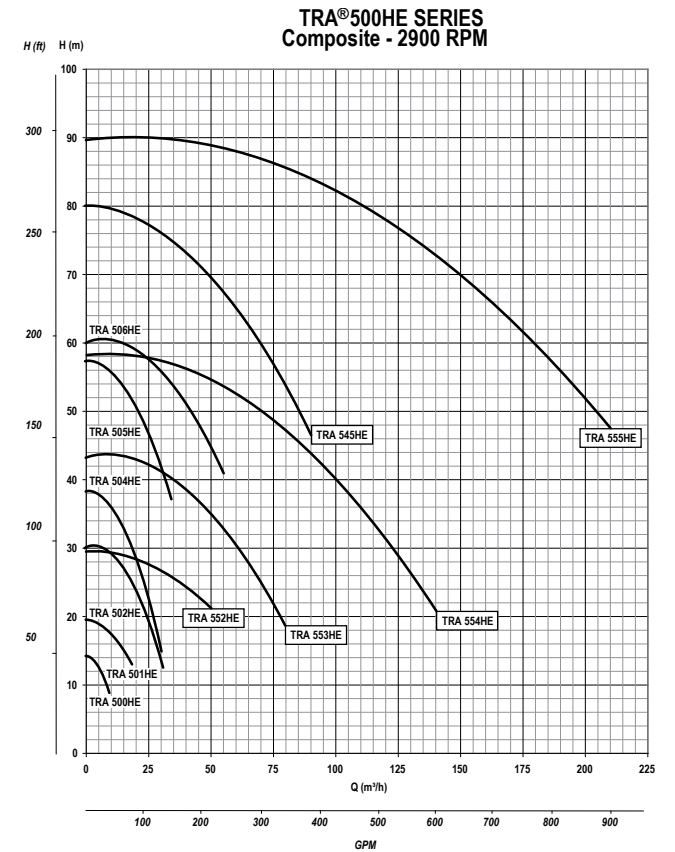
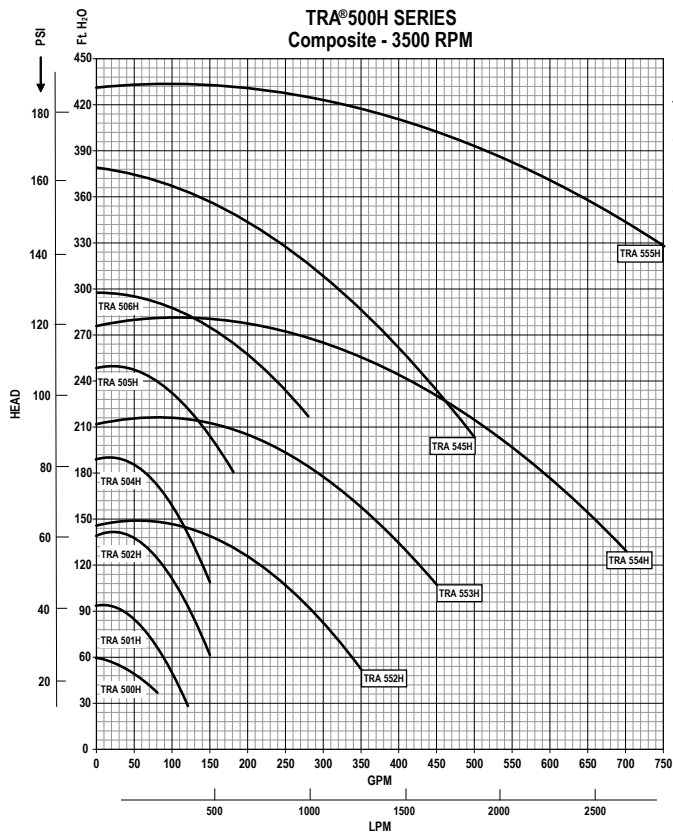
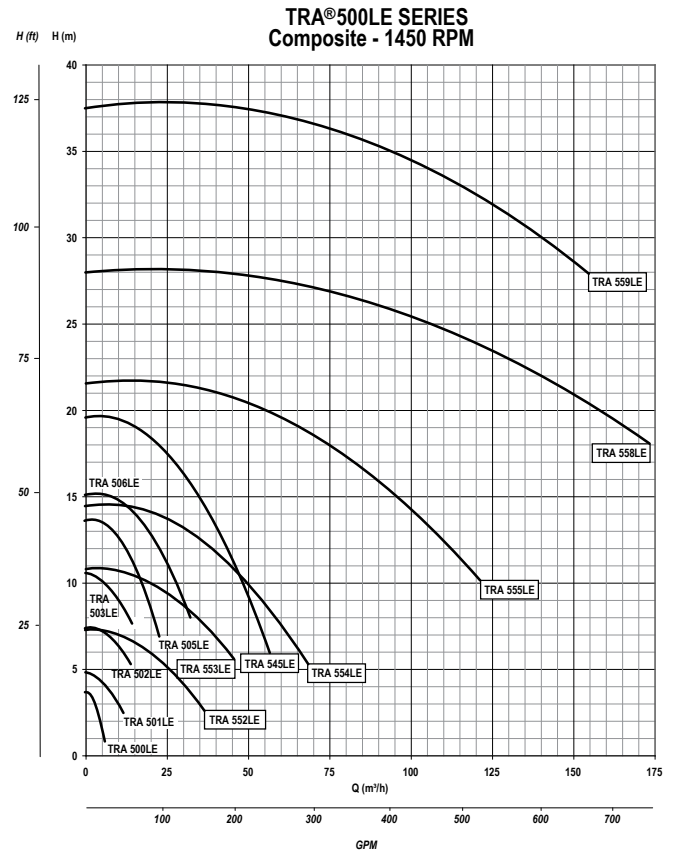
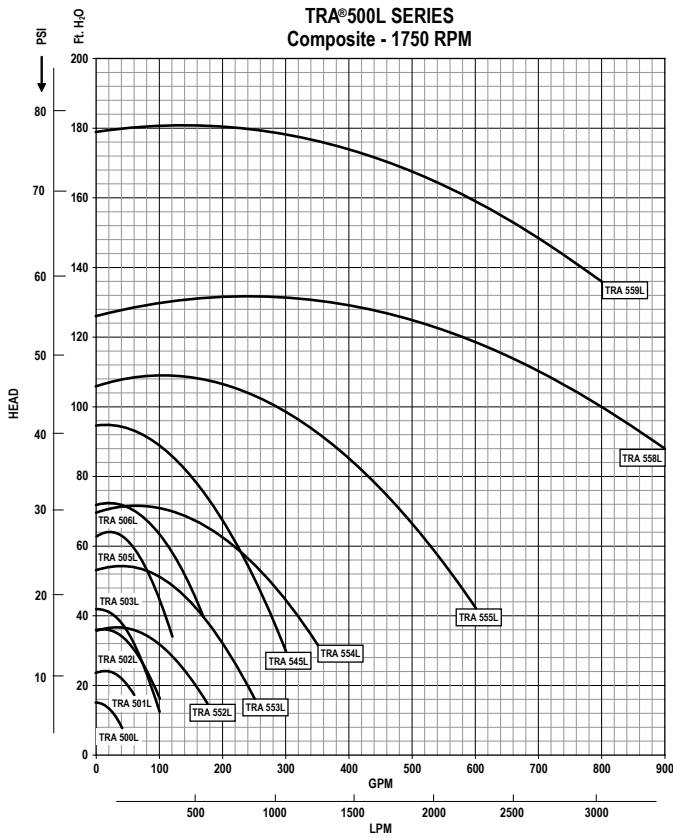

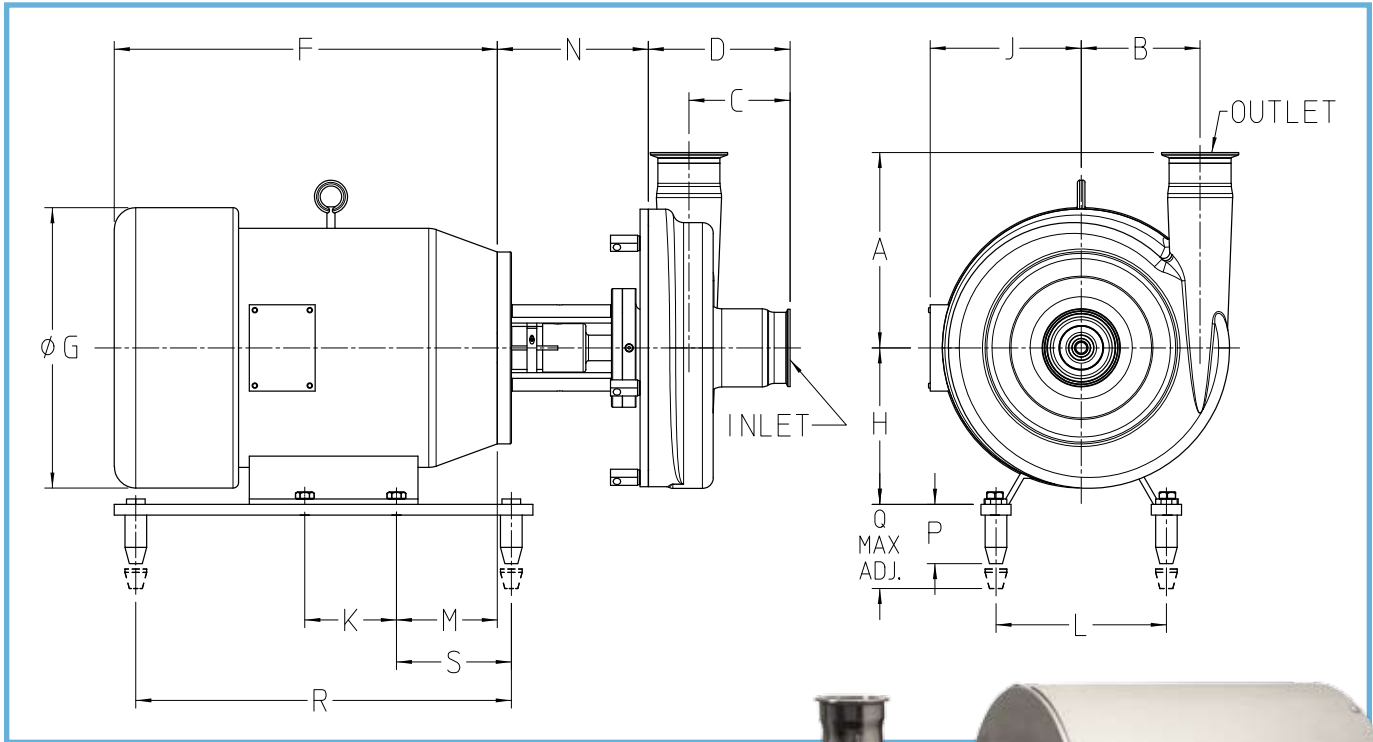

Dimensions: Pump

MODEL	INLET in (mm)	OUTLET in (mm)	A in (mm)	B in (mm)	C in (mm)	D in (mm)
TRA®500	1.50 (40)	1.50 (40)	4.30 (110)	1.75 (45)	4.31 (110)	5.00 (127)
TRA®501	2.00 (50)	1.50 (40)	5.69 (145)	2.25 (57)	4.44 (113)	5.25 (133)
TRA®502	2.00 (50)	1.50 (40)	6.69 (170)	3.13 (79)	4.44 (113)	5.13 (130)
TRA®503	2.00 (50)	1.50 (40)	6.69 (170)	3.13 (79)	4.44 (113)	5.13 (130)
TRA®504	2.50 (65)	2.00 (50)	7.69 (195)	3.75 (95)	4.00 (102)	5.00 (127)
TRA®505	2.50 (65)	2.00 (50)	7.69 (195)	3.75 (95)	4.00 (102)	5.00 (127)
TRA®506	2.50 (65)	2.00 (50)	7.88 (200)	3.69 (94)	4.25 (108)	5.13 (130)
TRA®552	2.50 (65)	2.00 (50)	7.50 (190)	3.13 (79)	4.63 (117)	6.00 (152)
TRA®553	2.50 (65)	2.00 (50)	7.50 (190)	3.75 (95)	4.56 (116)	6.00 (152)
TRA®554	3.00 (80)	2.50 (65)	8.25 (210)	4.50 (114)	4.63 (117)	6.00 (152)
TRA®545	3.00 (80)	2.00 (50)	8.25 (210)	5.50 (140)	4.69 (119)	5.88 (149)
TRA®555	3.00 (80)	2.50 (65)	9.06 (230)	5.50 (140)	4.69 (119)	6.25 (159)
TRA®558	4.00 (100)	4.00 (100)	9.88 (250)	6.69 (170)	4.31 (110)	6.25 (159)
TRA®559	4.00 (100)	4.00 (100)	9.88 (250)	6.69 (170)	4.31 (110)	6.25 (159)

Dimensions: Motor

MOTOR HP		MOTOR FRAME	F in (mm)	G in (mm)	H in (mm)	J in (mm)	K in (mm)	L in (mm)	M in (mm)	N in (mm)	P (MIN) in (mm)	Q (ADJ.) in (mm)
1750 RPM	3500 RPM											
0.5	0.5	56C	9.31 (237)	6.88 (175)	3.50 (89)	5.00 (127)	3.00 (76)	4.88 (124)	2.75 (70)	6.38 (162)	4.63 (118)	to 6.13 (156)
0.75	0.75	56C	9.31 (237)	6.88 (175)	3.50 (89)	5.00 (127)	3.00 (76)	4.88 (124)	2.75 (70)	6.38 (162)	4.63 (118)	to 6.13 (156)
1.0	1.0	56C	9.31 (237)	6.88 (175)	3.50 (89)	5.00 (127)	3.00 (76)	4.88 (124)	2.75 (70)	6.38 (162)	4.63 (118)	to 6.13 (156)
N/A	1.5	56C	9.31 (237)	6.88 (175)	3.50 (89)	5.00 (127)	3.00 (76)	4.88 (124)	2.75 (70)	6.38 (162)	4.63 (118)	to 6.13 (156)
1.5	N/A	145TC	11.25 (286)	7.19 (183)	3.50 (89)	5.25 (133)	5.00 (127)	5.50 (140)	2.25 (57)	6.38 (162)	4.63 (118)	to 6.13 (156)
2.0	2.0	145TC	11.25 (286)	7.19 (183)	3.50 (89)	5.25 (133)	5.00 (127)	5.50 (140)	2.25 (57)	6.38 (162)	4.63 (118)	to 6.13 (156)
N/A	3.0	145TC	11.25 (286)	7.19 (183)	3.50 (89)	5.25 (133)	5.00 (127)	5.50 (140)	2.25 (57)	6.38 (162)	4.63 (118)	to 6.13 (156)
3.0	N/A	182TC	12.31 (313)	8.50 (216)	4.50 (114)	5.88 (149)	4.50 (114)	7.50 (191)	2.75 (70)	7.69 (195)	4.63 (118)	to 6.13 (156)
5.0	5.0	184TC	12.31 (313)	8.50 (216)	4.50 (114)	5.88 (149)	5.50 (140)	7.50 (191)	2.75 (70)	7.69 (195)	4.63 (118)	to 6.13 (156)
N/A	7.5	184TC	15.19 (386)	8.50 (216)	4.50 (114)	5.88 (149)	5.50 (140)	7.50 (191)	2.75 (70)	7.69 (195)	4.63 (118)	to 6.13 (156)
7.5	7.5	213TC	12.31 (313)	10.19 (259)	5.25 (133)	7.38 (187)	5.50 (140)	8.50 (216)	3.50 (89)	7.69 (195)	4.63 (118)	to 6.13 (156)
N/A	10.0	215TC	12.31 (313)	10.19 (259)	5.25 (133)	7.38 (187)	7.00 (178)	8.50 (216)	3.50 (89)	7.69 (195)	4.63 (118)	to 6.13 (156)
10.0	15.0	215TC	16.06 (408)	10.19 (259)	5.25 (133)	7.38 (187)	7.00 (178)	8.50 (216)	3.50 (89)	7.69 (195)	4.63 (118)	to 6.13 (156)
15.0	N/A	254TC	19.75 (502)	13.25 (337)	6.25 (159)	9.63 (245)	8.30 (210)	10.00 (254)	4.25 (108)	7.69 (195)	4.63 (118)	to 6.13 (156)
20.0	20.0	256TC	19.75 (502)	13.25 (337)	6.25 (159)	9.63 (245)	10.00 (254)	10.00 (254)	4.25 (108)	7.69 (195)	4.63 (118)	to 6.13 (156)
25.0	N/A	284TC	23.00 (584)	14.19 (360)	7.00 (178)	13.13 (333)	9.50 (241)	11.00 (279)	4.75 (121)	7.69 (195)	4.63 (118)	to 6.13 (156)
N/A	25.0	284TSC	23.00 (584)	14.19 (360)	7.00 (178)	13.13 (333)	9.50 (241)	11.00 (279)	4.75 (121)	7.69 (195)	4.63 (118)	to 6.13 (156)
30.0	N/A	286TC	23.00 (584)	14.19 (360)	7.00 (178)	13.13 (333)	11.00 (279)	11.00 (279)	4.75 (121)	7.69 (195)	4.63 (118)	to 6.13 (156)
N/A	30.0	286TSC	23.00 (584)	14.19 (360)	7.00 (178)	13.13 (333)	11.00 (279)	11.00 (279)	4.75 (121)	7.69 (195)	4.63 (118)	to 6.13 (156)
40.0	N/A	324TC	25.00 (635)	16.13 (410)	8.00 (203)	17.13 (359)	10.50 (267)	12.50 (318)	5.25 (133)	8.50 (216)	4.63 (118)	to 6.13 (156)
N/A	40.0	324TSC	25.00 (635)	16.13 (410)	8.00 (203)	17.13 (359)	10.50 (267)	12.50 (318)	5.25 (133)	8.50 (216)	4.63 (118)	to 6.13 (156)
50.0	N/A	326TC	25.00 (635)	16.13 (410)	8.00 (203)	17.13 (359)	12.00 (305)	12.50 (318)	5.25 (133)	8.50 (216)	4.63 (118)	to 6.13 (156)
N/A	50	326TSC	25.00 (635)	16.13 (410)	8.00 (203)	17.13 (359)	12.00 (305)	12.50 (318)	5.25 (133)	8.50 (216)	4.63 (118)	to 6.13 (156)

MOTOR KW		MOTOR FRAME	F in (mm)	G in (mm)	H in (mm)	J in (mm)	K in (mm)	L in (mm)	M in (mm)	N in (mm)	P (MIN) in (mm)	Q (ADJ.) in (mm)
1450 RPM	2900 RPM											
0.37	0.37	80	8.46 (215)	6.69 (170)	3.15 (80)	4.510 (116)	3.937 (100)	4.921 (125)	1.969 (50)	6.38 (162)	4.63 (118)	to 6.13 (156)
0.55	0.55	80	8.46 (215)	6.69 (170)	3.15 (80)	4.510 (116)	3.937 (100)	4.921 (125)	2.969 (50)	6.38 (162)	4.63 (118)	to 6.13 (156)
0.75	0.75	80	8.46 (215)	6.69 (170)	3.15 (80)	4.510 (116)	3.937 (100)	4.921 (125)	2.969 (50)	6.38 (162)	4.63 (118)	to 6.13 (156)
N/A	1.1	80	8.46 (215)	6.69 (170)	3.15 (80)	4.510 (116)	3.937 (100)	4.921 (125)	2.969 (50)	6.38 (162)	4.63 (118)	to 6.13 (156)
1.1	N/A	90L	9.65 (245)	7.48 (190)	3.543 (90)	5.120 (130)	9.37 (100) / 4.92 (125)	5.511 (140)	2.205 (56)	6.38 (162)	4.63 (118)	to 6.13 (156)
1.5	1.5	90L	9.65 (245)	7.48 (190)	3.543 (90)	5.120 (130)	9.37 (100) / 4.92 (125)	5.511 (140)	2.205 (56)	6.38 (162)	4.63 (118)	to 6.13 (156)
N/A	2.2	90L	9.65 (245)	7.48 (190)	3.543 (90)	5.120 (130)	9.37 (100) / 4.92 (125)	5.511 (140)	2.205 (56)	6.38 (162)	4.63 (118)	to 6.13 (156)
2.2	N/A	112S	12.4 (315)	9.25 (235)	4.409 (112)	5.875 (149)	4.49 (114) / 5.51 (140)	7.48 (190)	2.760 (70)	7.69 (195)	4.63 (118)	to 6.13 (156)
3.7	3.7	112M	13.15 (334)	9.25 (235)	4.409 (112)	5.875 (149)	4.49 (114) / 5.51 (140)	7.48 (190)	2.760 (70)	7.69 (195)	4.63 (118)	to 6.13 (156)
N/A	5.5	112M	13.15 (334)	9.25 (235)	4.409 (112)	5.875 (149)	4.49 (114) / 5.51 (140)	7.48 (190)	2.760 (70)	7.69 (195)	4.63 (118)	to 6.13 (156)
5.5	5.5	132S	13.78 (350)	9.25 (235)	5.197 (132)	7.375 (187)	5.51 (140) / 7.01 (178)	8.504 (216)	3.504 (89)	7.69 (195)	4.63 (118)	to 6.13 (156)
N/A	7.5	132M	15.24 (387)	11.02 (280)	5.197 (132)	7.375 (187)	5.51 (140) / 7.01 (178)	8.504 (216)	3.504 (89)	7.69 (195)	4.63 (118)	to 6.13 (156)
7.5	11	132M	15.24 (387)	11.02 (280)	5.197 (132)	7.375 (187)	5.51 (140) / 7.01 (178)	8.504 (216)	3.504 (89)	7.69 (195)	4.63 (118)	to 6.13 (156)
11	N/A	160M	19.49 (495)	12.44 (316)	6.299 (160)	9.510 (242)	8.27 (210) / 10 (254)	10 (254)	4.252 (108)	7.69 (195)	4.63 (118)	to 6.13 (156)
15	15	160L	19.49 (495)	12.44 (316)	6.299 (160)	9.510 (242)	8.27 (210) / 10 (254)	10 (254)	4.252 (108)	7.69 (195)	4.63 (118)	to 6.13 (156)
18.5	N/A	180M	19.49 (495)	12.44 (316)	7.087 (180)	13.120 (333)	9.49 (241) / 10.98 (279)	10.984 (279)	4.764 (121)	7.69 (195)	4.63 (118)	to 6.13 (156)
N/A	18.5	180M	19.49 (495)	12.44 (316)	7.087 (180)	13.120 (333)	9.49 (241) / 10.98 (279)	10.984 (279)	4.764 (121)	7.69 (195)	4.63 (118)	to 6.13 (156)
22	N/A	180L	23.34 (593)	13.78 (350)	7.087 (180)	13.120 (333)	9.49 (241) / 10.98 (279)	10.984 (279)	4.764 (121)	7.69 (195)	4.63 (118)	to 6.13 (156)
N/A	22	180L	23.34 (593)	13.78 (350)	7.087 (180)	13.120 (333)	9.49 (241) / 10.98 (279)	10.984 (279)	4.764 (121)	7.69 (195)	4.63 (118)	to 6.13 (156)
30	N/A	200M	23.58 (599)	15.35 (390)	7.874 (200)	14.125 (359)	10.51 (267) / 12 (305)	12.520 (318)	5.236 (133)	**	4.63 (118)	to 6.13 (156)
N/A	30	200M	23.58 (599)	15.35 (390)	7.874 (200)	14.125 (359)	10.51 (267) / 12 (305)	12.520 (318)	5.236 (133)	**	4.63 (118)	to 6.13 (156)
37	N/A	200L	24.45 (621)	15.35 (390)	7.874 (200)	14.125 (359)	10.51 (267) / 12 (305)	12.520 (318)	5.236 (133)	**	4.63 (118)	to 6.13 (156)
N/A	37	200L	24.45 (621)	15.35 (390)	7.874 (200)	14.125 (359)	10.51 (267) / 12 (305)	12.520 (318)	5.236 (133)	**	4.63 (118)	to 6.13 (156)

NOTE:

** Contact factory.

Motor dimensions may vary by manufacturer.

Pump dimensions are based on clamp fittings. Consult factory for other fitting options.

Dimensions are based on comparisons between IEC and NEMA standards.

Sanitary Pumps, Parts, Remanufacturing & Accessories

For more information, contact your local authorized Wright Flow Technologies Distributor or contact us at:



WRIGHT PUMP, INC.

A Unit of IDEX Corporation
S84 W18693 Enterprise Drive
Muskego, WI 53150
Telephone: (262) 679-8000
Fax: (262) 679-2026
Email: info.wright@idexcorp.com
Web Site: www.wrightpump.com

JOHNSON PUMP (UK) LTD.

A Unit of IDEX Corporation
Highfield Industrial Estate
Edison Road
Eastbourne
East Sussex, United Kingdom
Telephone: +44 1323 509211
Fax: +44 1323 507306
E-mail: jinfo@idexcorp.com
Web Site: www.johnsonpump.com

LATIN AMERICA

D.F. Mexico C.F.
Phone: +52 (5) 5255-1357
Fax: +52 (5) 5255-1356

EUROPE

Shannon, Ireland
Phone: +353 (61) 471933
Fax: +353 (61) 475046

MIDDLE EAST

Dubai - UAE
Phone: +971-4-2257978
Fax: +971-4-2259796

ASIA-PACIFIC GROUP

Singapore
Phone: +65-6763-6633
Fax: +65-6764-4020

ASIA-PACIFIC GROUP

China - Beijing
Phone: +86-10-6522-7567/27
Fax: +86-10-6522-7563

ASIA-PACIFIC GROUP

China - Shanghai
Phone: +86-21-5241-5599
Fax: +86-21-5241-8339

ASIA-PACIFIC GROUP

China - Guangzhou
Phone: +86-20-3886-6156
Fax: +86-20-3886-2776

ASIA-PACIFIC GROUP

India - Mumbai
Phone: +91-22-6678-0048/53
Fax: +91-22-6678-0055